

PN 16 CAST IRON GATE VALVE

(Rising stem) Outside Screw & Yoke

	STANDARDS
DESIGN STANDARD	ANSI B16.10
END CONNECTION	ANSI B16.1
END TO END	API 6D / JIS 10K / MSS SP 70
TESTING STANDARD	API 598

Applications: Regulation & Control of Oil & Gas Pipelines, Water Supply Systems, Chemical Plants, and others Industrial Applications to Control the Flow of Liquids.

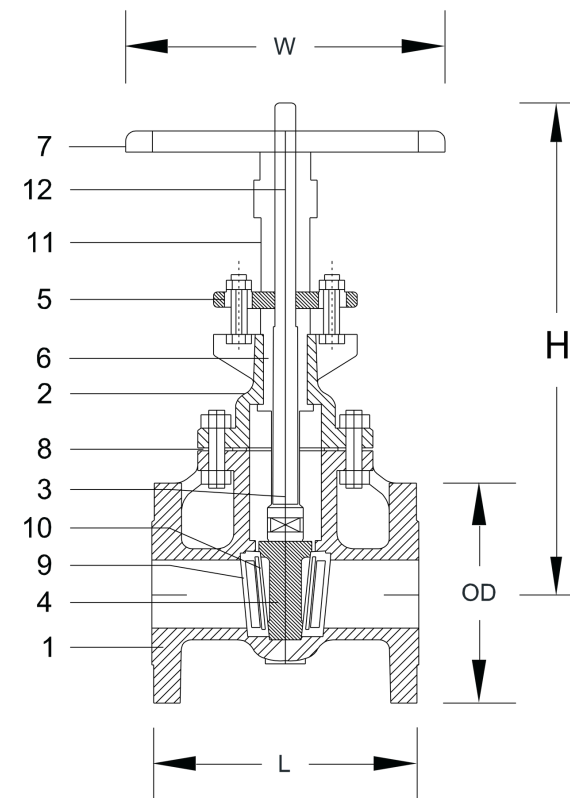

	COMPONENT	SPECIFICATIONS	
1	BODY	CAST IRON (A126 CLASS B)	
2	BONNET	CAST IRON (A126 CLASS B)	
3	STEM	STAINLESS STEEL 420 / EN 1.402 1	BRONZE
4	DISC	For < 8" STAINLESS STEEL 420 / EN 1.4021 For > 8" CAST IRON (A 126 Class B)	
5	GLAND	CAST IRON / CARBON STEEL	
6	GLAND PACKING	FLEXIBLE GRAPHITE	
7	HAND WHEEL	CAST IRON / CARBON STEEL	
8	GASKET	NON ASBESTOS SHEET	
9	BODY SEAT RING	STAINLESS STEEL 420 / EN 1.4021	BRONZE
10	DISC SEAT RING	STAINLESS STEEL 420 / EN 1.4021	BRONZE
11	YOKE	CAST IRON (A126 CLASS B)	
12	YOKE SLEEVE	CAST BRASS	BRONZE

Dimensions in mm

DN	40	50	65	80	100	125	150	200	250	300	350	400	450	500	600	700
L	165	178	190	203	229	254	267	292	330	356	381	406	432	457	508	610
OD	130	150	180	190	230	255	280	345	405	485	535	600	635	700	815	927
H	270	320	360	400	470	530	650	800	960	1150	1310	1500	1600	1770	2100	2600
W	200	200	200	230	250	250	290	290	400	480	480	600	600	600	700	1000